

BSF I



CATEGORY: Forestry / Agricultural
WORKING WIDTH (m): 1.8 – 3.8
FLAIL MOWER: Rear

THE SEMI-FORESTRY FLAIL MOWER FOR SHREDDING IN TOUGH, HARSH CONDITIONS

The BSF I flail mower is specially designed for shredding brush and branches up to 12 cm in diameter. Its hydraulically-controlled rear cover is ideal for taking in large masses of greenery and when closed, it shreds the matter very finely and evenly. In addition, the roller (optional) is fixed on the cover and thus rises at the same time to free the opening. The low power absorption, rugged construction and great versatility offered by the BSF I flail mower makes it a particularly popular purchase.

THE STANDARD ESSENTIALS



- 240 HP gearbox with integrated free wheel
- Reinforced body structure, 5-mm base, 10-mm side walls
- 5-mm welded high tensile steel sheet lining
- Large-dimension rotor (Ø 60-mm shaft, Ø 300-mm tube rotor)
- Rotor bearings with double row of rollers
- Versatile wide, heavy hammers with M20 class 12.9 screw
- Rounded, height-adjustable high tensile steel skids
- Hydraulically controlled rear cover
- Front protection with double chain guard

The options → Ø 220-mm working roller fixed to cover

CUTTING HEADS



Wide hammers

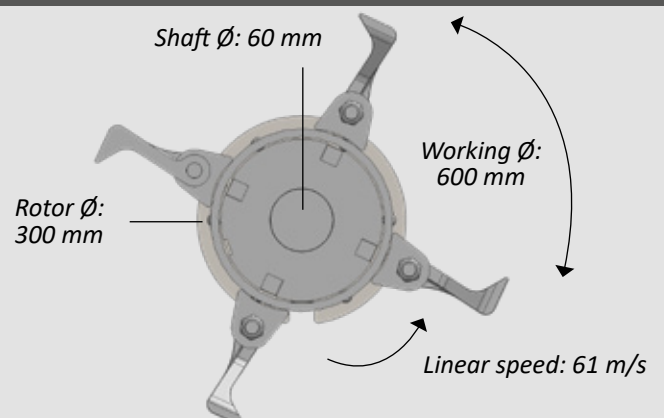

		BSF I 180	BSF I 200	BSF I 220	BSF I 240	BSF I 260	BSF I 280	BSF I 300
Dimensions	Working width (m)	1.80	2.00	2.20	2.40	2.60	2.80	3.00
	Overall width (m)	2.05	2.25	2.45	2.65	2.85	3.05	3.25
	Working Ø (mm)	600	600	600	600	600	600	600
	Rotor Ø (mm)	300	300	300	300	300	300	300
	Rotor Shaft Ø (mm)	60	60	60	60	60	60	60
	Type of hitch	CAT 2	CAT 2	CAT 2	CAT 2	CAT 2	CAT 2	CAT 2
	Body structure	Body base 5 mm, side walls 10 mm						
	Sheet metal lining	5 mm welded						
	Ground following	Height-adjustable skids (Ø 220-mm roller optional)						
	Weight (kg)	1085	1145	1205	1265	1325	1385	1445
Tools	No. of wide hammers	16	20	20	24	24	26	30
	Hammer shaft Ø (mm)	M20 fine screw thread						
Features	Gearbox (HP)	240	240	240	240	240	240	240
	Rotor rotation speed (rpm)	1822	1822	1822	1822	1822	1822	1822
	Linear speed of cutting heads (m/s)	61	61	61	61	61	61	61
	Material input and ejection	Hydraulically-opened rear cover standard Rear roller fixed on cover (optional)						
	PTO (rpm)	1000	1000	1000	1000	1000	1000	1000
	PTO shaft	1" 3/8, 6 splines with free wheels						
	No. of belts	3	4	4	4	4	5	5
	Front protection	Double chain guard standard						
	Required power (HP)	110	120	130	140	150	160	170
Options	Rear roller	○	○	○	○	○	○	○

● Standard – Not available ○ Optional

WIDTHS

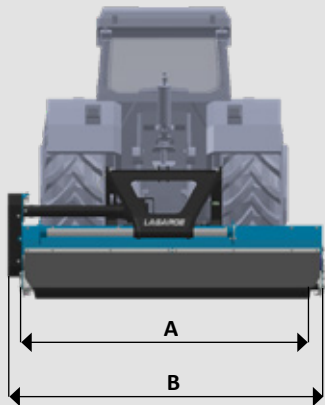

Widths in mm		BSF I 180	BSF I 200	BSF I 220	BSF I 240	BSF I 260	BSF I 280	BSF I 300
Working	A	1800	2000	2200	2400	2600	2800	3000
	B	2050	2250	2450	2650	2850	3050	3250



Equipment designed to last

LAGARDE - 65 Avenue de Tréville - 64130 Mauléon Licharre

Tél : +33 5 59 19 20 10 - Fax : +33 5 59 19 20 11 - accueil@lagarde.artzainak.fr



Your LAGARDE dealer