

GM III

CATEGORY: **Agricultural / Landscape maintenance**

WORKING WIDTH (m): **2.50 – 3.10**

FLAIL MOWER: **Front / Rear / Front and rear**

MORE DETAILS
www.lagarde-sas.fr



A HEAVY-DUTY FLAIL MOWER FOR INTENSIVE USE

The GM III range of flail mowers offers outstanding shredding, ruggedness and leading-edge design. The GM III is the versatile flail mower chosen by users demanding high quality, fine, even shredding. Economic considerations, such as high throughput tasks and low maintenance costs also play a part in their selection.

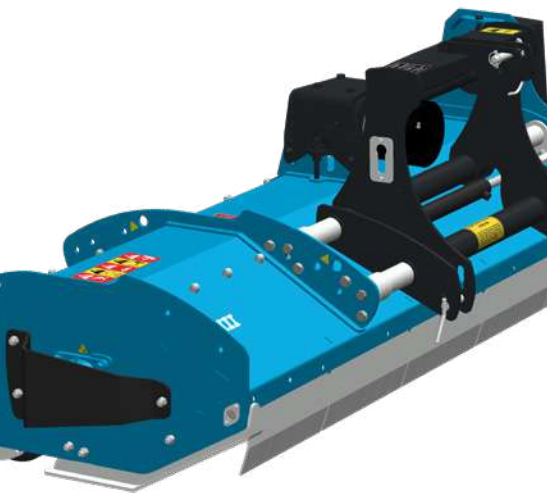

THE STANDARD ESSENTIALS

- Gear box with free wheel up to 240 HP, available in 540 or 1000 rpm versions
- Profiled housing and body to protect the structure and drive gear
- Single HTS steel hitch
- Manual offset of 500 mm by sliding along 2 detachable bichromate tubes
- Protected external bearings with baffle to prevent wire and twine clogging
- \varnothing 245-mm self-cleaning working roller with self-aligning bearings
- HDX steel skids
- Transmission via Very High Performance (VHP) belts

The options →hydraulic offset, Hardox sheet metal lining, signalling kit, etc.

KINEMATICS

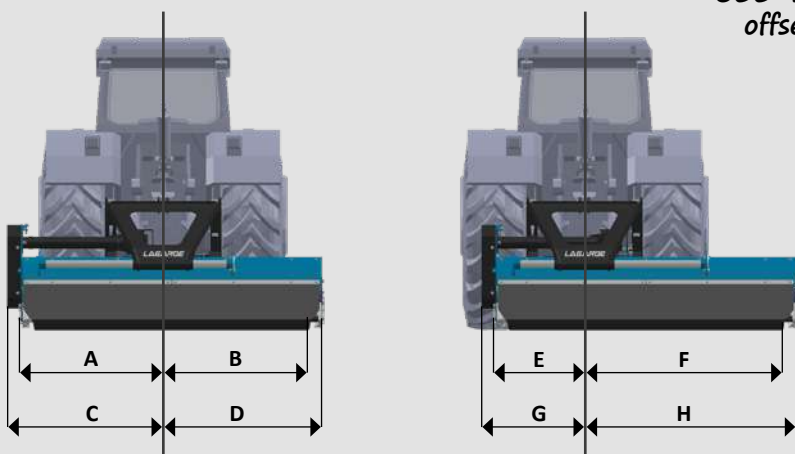

500-mm
offset

		Widths in mm	GM III 250	GM III 280	GM III 310
LH offset	Overall	A	1220	1370	1490
		B	1280	1430	1610
	Working	C	1396	1546	1666
		D	1397	1547	1727
RH offset	Overall	E	720	870	990
		F	1780	1930	2110
	Working	G	896	1046	1166
		H	1897	2047	2227



HITCH

- CAT 2 hitch with 500-mm offset on two \varnothing 70-mm beams
- Rugged hitch made of 12-mm thick HTS steel
- Two possibilities: rear hitch and double hitch (optional)

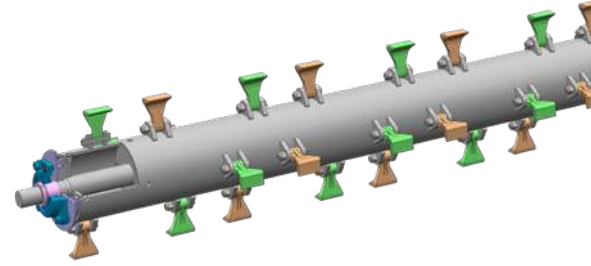

ROTOR & ROTOR BEARINGS

Double helicoidal system rotor

- Smoother engagement when starting, perfect drive torque linearity when working
- Regular updraft, does not flatten the vegetation before shredding it
- Oversized bearings
- Baffle protection to prevent wire and twine clogging

TRANSMISSION

- 540 or 1000 rpm by pulley inversion
- Use of Very High Performance (VHP) belts

Service life twice as long

Service life three times as long

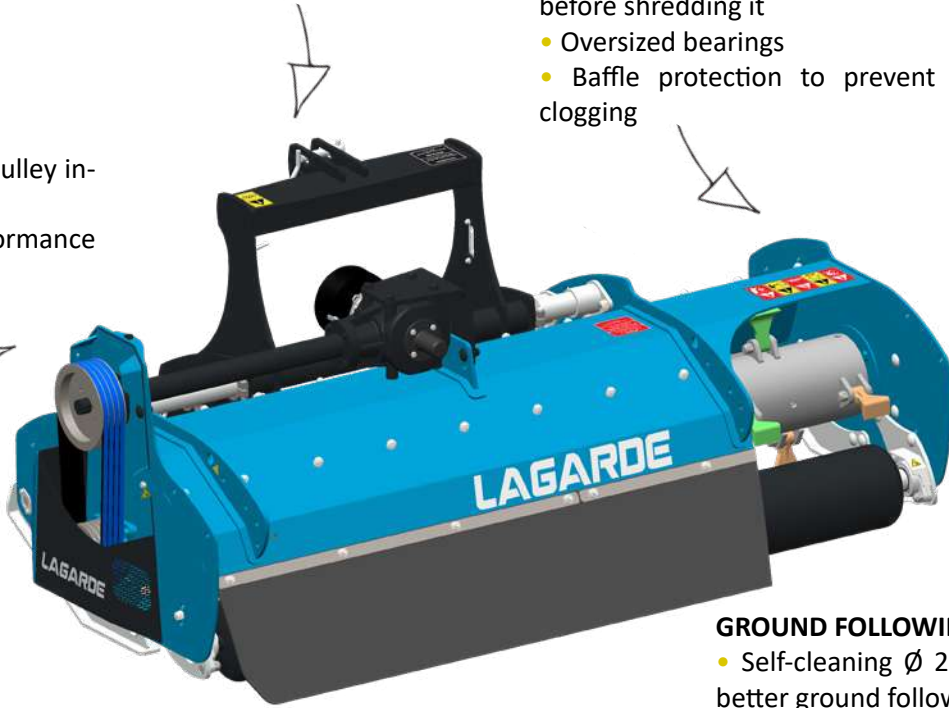

GROUND FOLLOWING

- Self-cleaning \varnothing 245-mm roller for better ground following

WEAR PARTS

- HDX skids standard
- Optional HDX sheet metal lining

Optional 360° swivel front or rear wheels



BODY

- Rugged HTS steel body: 8-mm side wall, 5-mm thick body base, 12-mm transverse braces, front and rear structure boxes
- 3.2-mm bolted HDX steel metal lining, optional
- Body profile designed for excellent updraft and extremely fine shredding (1st counter-blade standard, 2nd counter blade optional)

CUTTING HEADS



Hammers

Y-blades

Spoon blades

Universal rotor

++ Specially developed shape to protect the rotor

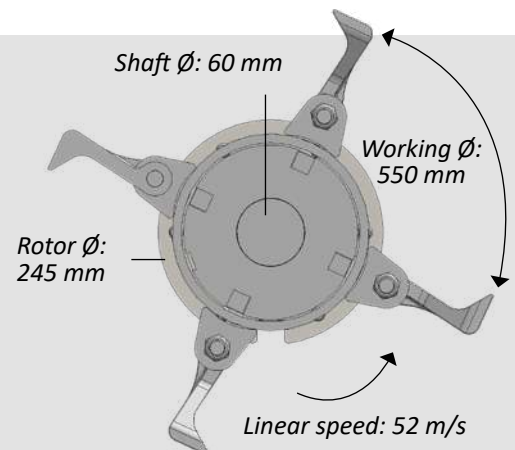

		GM III 250	GM III 280	GM III 310
Dimensions	Working width (m)	2.50	2.80	3.10
	Overall width (m)	2.75	3.00	3.35
	Working Ø (mm)	550	550	550
	Type of hitch	Axial hitch, CAT 2, sliding 3rd point		
	Offset to the right (mm)	500	500	500
	Body structure	8.2-mm body base (5 mm + bolted HDX 3.2-mm sheet metal lining, optional), 8-mm side walls		
	Ground following	Ø 245-mm roller, high strength steel side skids		
	Weight (kg)	1285	1380	1475
Tools	No. of hammers	32	36	40
	No. of Y blades	64	72	80
	No. of spoon blades	32	36	40
Features	Gearbox (HP)	160 CV at 540 rpm and 240 CV at 1000 rpm		
	Rotor rotation speed (rpm)	1850	1850	1850
	Linear speed of cutting heads (m/s)	52	52	52
	PTO (rpm)	540 or 1000	540 or 1000	540 or 1000
	PTO shaft	1" 3/8, 6 splines, star tube		
	Counter-blade	Bolted		
	No. of belts	4	4	4
	Required power (HP)	70	85	95
Options	Double hitch	○	○	○
	Reverse drive controls	○	○	○
	Hydraulic offset	○	○	○
	1000 rpm drive	○	○	○
	Bolted HDX sheet metal lining	○	○	○
	Additional counter-blade	○	○	○
	Vibration hour meter	○	○	○
	Magnetic hour meter	○	○	○
	360° rear wheels	○	○	○
	Chain guard	○	○	○
	Rear flap	○	○	○
	Road signalling kit	○	○	○
	Set of cutting heads	○	○	○

● Standard – Not available ○ Optional



Equipment designed to last

LAGARDE - 65 Avenue de Tréville - 64130 Mauléon Licharre

Tél : +33 5 59 19 20 10 - Fax : +33 5 59 19 20 11 - accueil@lagarde.artzainak.fr



Your LAGARDE dealer