

MB III

CATEGORY: **Agricultural / Landscape maintenance**

WORKING WIDTH (m): **1.60 - 2.30**

FLAIL MOWER: **Rear**

MORE DETAILS
www.lagarde-sas.fr



THE HEAVY-DUTY ROADSIDE VERGE MOWER

Single-arm MBIII verge mowers are new-generation implements, specially designed to meet the needs of users such as local authorities, farm work contractors and machinery pooling cooperatives.

THE STANDARD ESSENTIALS



- 145 HP gearbox with integrated free wheel
- HTS steel body structure strengthened by front and rear housing
- Exceptional 1.80-m lateral offset
- Parallelogram on 215x135 mm beam and Ø 50-mm shafts
- Front hydraulic security to deflect obstacles, rear deflection optional
- Massive rotor (Ø 55-mm shafts, Ø 170-mm tube rotor)
- Bearings protected with baffles to prevent wire and twine clogging
- Low-mounted unit (520 mm) and internal bearings
- Belt housing fitted with protective cover
- The cutting tools pass as close to the self-cleaning roller as possible

The options →HDX sheet metal lining, pro roller with removable ends, etc.

KINEMATICS

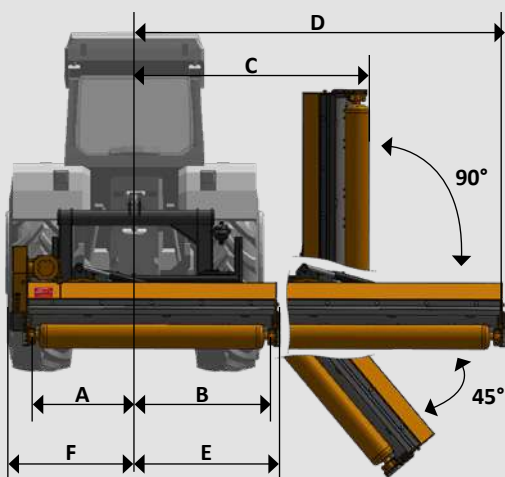

Widths in mm		MB III 160	MB III 180	MB III 200	MB III 230
Working	A	875	875	875	875
	B	725	925	1125	1425
	C	1885	1885	1885	1885
Overall	D	2580	2780	2980	3280
	E	780	980	1180	1480
	F	1010	1010	1010	1010

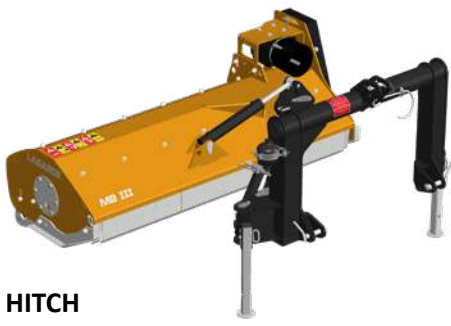

HITCH

- CAT 2 hitch, sliding 3rd point
- Rugged steel hitch

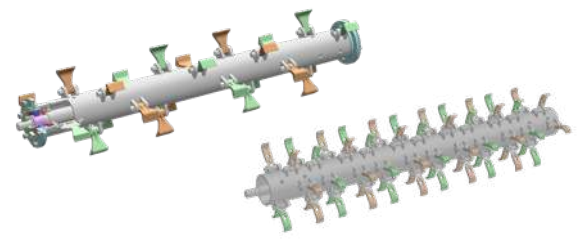

ROTOR & ROTOR BEARINGS

- Double helicoidal system rotor with high linear speed for strong updraft and excellent cutting quality
- Wide diameter tube rotor: \varnothing 170 mm
- Oversized bearings
- Baffle protection to prevent wire and twine clogging

TRANSMISSION

- 540 rpm
- Use of Very High Performance (VHP) belts

Service life twice as long

Service life three times as long

WEAR PARTS

- HDX skids standard
- Optional HDX sheet metal lining



WORKING ROLLER

- Self-cleaning \varnothing 195-mm roller for better ground following

PRO roller with optional removable ends

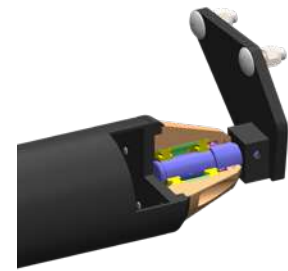

BODY

- Rugged HTS steel body: 8-mm side walls, 6-mm body base, front and rear housings
- Body profile designed for excellent updraft and extremely fine shredding (1st counter-blade standard, 2nd counter blade optional)

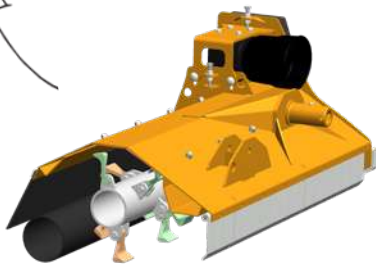

CUTTING HEADS



Hammers

Y-blades

Universal rotor



Pallet blades

Mowing rotor

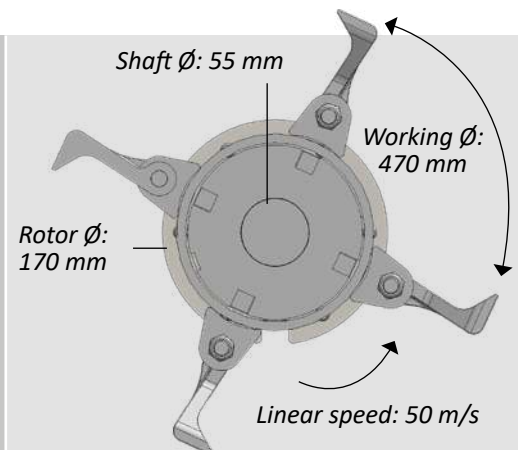

		MB III 160	MB III 180	MB III 200	MB III 230
Dimensions	Working width (m)	1.60	1.80	2.00	2.30
	Transport width (m)	1.80	2.00	2.20	2.50
	Working Ø (mm)	490	490	490	490
	Type of hitch	CAT 2 hitch, sliding 3rd point			
	Cutting height (cm)	3, 6 and 9			
	Parallelogram beams (mm)	215 x 135			
	Beam shafts (mm)	Ø50	Ø50	Ø50	Ø50
	Offset to the right (mm)	1800	1800	1800	1800
	Slope	+90° to -45°			
	Body structure	6-mm body base, 8-mm side walls + bolted HDX 3.2-mm sheet metal lining, optional			
	Ground following	Ø 194-mm roller and HDX side skids			
	Follower roll bearings	Self-aligning bearings			
	Weight (kg)	910	940	970	1015
Cutting heads	No. of hammers	20	22	24	28
	No. of Y blades	40	44	48	56
	No. of pallet blades	52	60	66	50 (pallet blades + 50-mm wide pallet blades)
Features	Gearbox (HP)	145	145	145	145
	Rotor rotation speed (rpm)	2000	2000	2000	2000
	Linear speed of cutting heads (m/s)	50	50	50	50
	Front protection	Projectile guards			
	Ejection of shredded matter	Removable rear baffle			
	Rotor bearings	Internal			
	PTO (rpm)	540	540	540	540
	PTO shaft	1'3/8, 6 splines			
	Security	Hydraulic front, rear optional			
	No. of belts	4	4	4	4
	Required power (HP)	65 / 80	70 / 85	75 / 90	80/95
	Options	Double homokinetic joint	○	○	○
Rear flap instead of baffle		○	○	○	○
HDX sheet metal lining		○	○	○	○
Front flap		○	○	○	○
Hydraulic breakaway safety feature front and rear		○	○	○	○
Second counter-blade		○	○	○	○
PRO roller with removable ends		○	○	○	○
Vibration hour meter		○	○	○	○
Magnetic hour meter		○	○	○	○
Road signalling kit (reflective stripes)		○	○	○	○

● Standard – Not available ○ Optional



Equipment designed to last

LAGARDE - 65 Avenue de Tréville - 64130 Mauléon Licharre

Tél : +33 5 59 19 20 10 - Fax : +33 5 59 19 20 11 - accueil@lagarde.artzainak.fr



Your LAGARDE dealer