

GB III

CATEGORY: **Agricultural**
WORKING WIDTH (m): **2,20 - 3,10**
FLAIL MOWER: **Rear**

MORE DETAILS
www.lagarde-sas.fr



AN EXCELLENT FLAIL MOWER FOR VERSATILITY THAT'S SECOND TO NONE

The GB III rotary mower shreds finely, making it ideal for grassland and orchard maintenance, and for shredding brush and crop residue. The adjustable cover, hydraulic offset and wide choice of cutting heads make it a highly versatile flail mower.

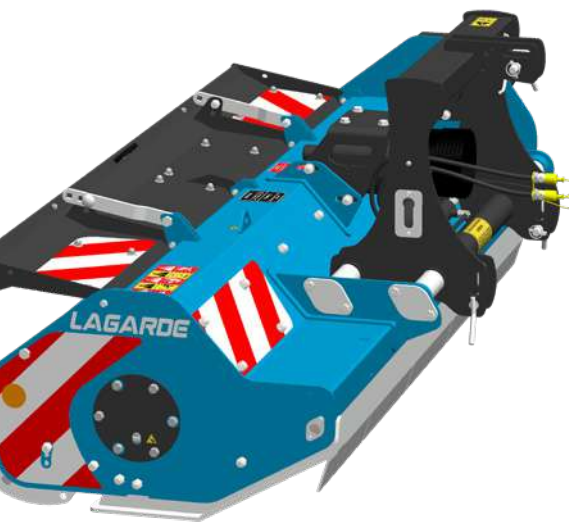

THE STANDARD ESSENTIALS

- Gearbox with free wheel up to 240 HP, available in 540 or 1000 rpm versions
- Rear cover opens for easy maintenance
- Rear hitch, with floating third point
- 500-mm offset, sliding mechanism on 2 detachable bichromate tubes
- Interior bearings with baffle protection to prevent wire and twine clogging
- Ø 195-mm self-cleaning working roller with self-aligning bearings
- HDX steel skids
- Transmission via high-performance V-belts

The options →hydraulic offset, body with sheet metal lining and Hardox cover

KINEMATICS

500-mm offset

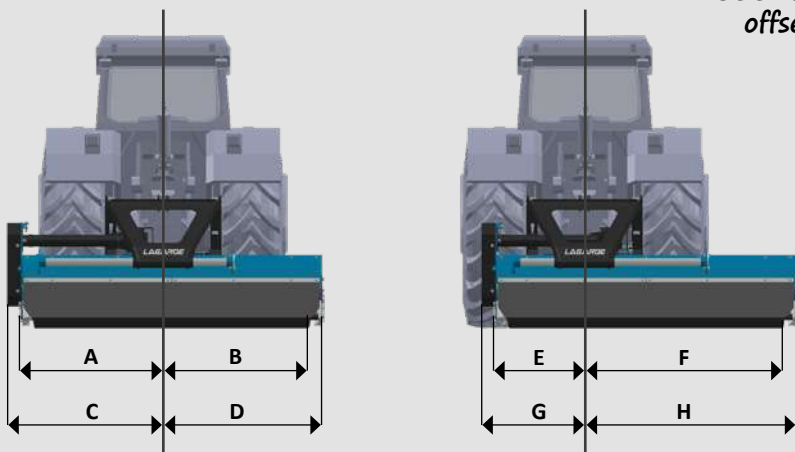

Widths in mm		GB III 220	GB III 250	GB III 280	GB III 310	
LH Offset	Overall A	A	1210	1250	1400	1550
		B	990	1250	1400	1550
	Working	C	1350	1390	1540	1690
		D	1021	1281	1431	1581
RH offset	Overall A	E	710	750	900	1050
		F	1490	1750	1900	2050
	Working	G	850	890	1040	1190
		H	1521	1781	1931	2081

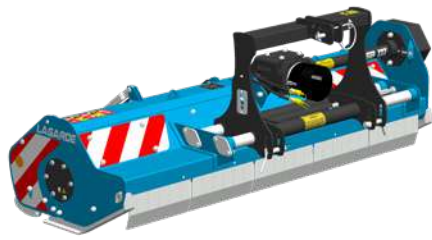

HITCH

- Can be offset, double beam CAT2
- 500-mm hydraulic offset optional
- Rugged in 12-mm thick HTS steel
- Rear hitch

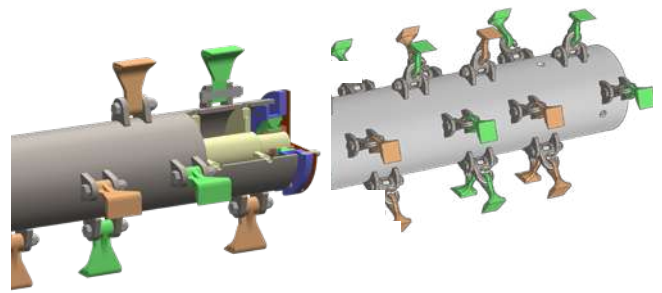

ROTOR & ROTOR BEARINGS

- Universal rotor or mowing rotor offer high linear speed for strong updraft and excellent cutting quality
- Ø 220-mm tube rotor
- Internal bearings, oversized ball bearings
- Baffle protection to prevent wire and twine clogging

TRANSMISSION

- 540 or 1000 rpm by pulley inversion
- Use of Very High Performance (VHP) belts

Service life twice as long

Service life three times as long



COVER

- Optional hydraulically-opened from the cab

WORKING ROLLER

- Self-cleaning Ø 195-mm roller for better ground following

WEAR PARTS

- HDX skids standard
- Optional HDX sheet metal lining

360° swivel wheels at the rear, optional

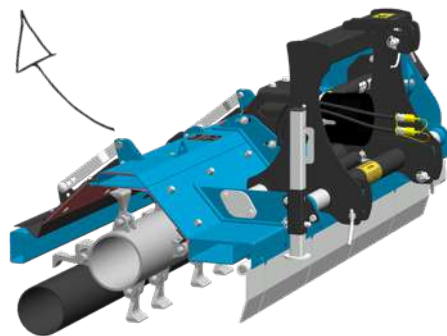

BODY

- Rugged HTS steel body: 8-mm side wall, 5-mm thick body base, 12-mm transverse braces, front and rear structure boxes
- 3.2-mm bolted HDX steel metal lining, optional
- Body profile designed for excellent updraft and extremely fine shredding (1st counter-blade standard, 2nd counter blade optional)

CUTTING HEADS



Hammers Y-blades Spoon blades
Universal rotor



Pallet blades Quick-change Y-blades Quick-change sickles
Mowing rotor

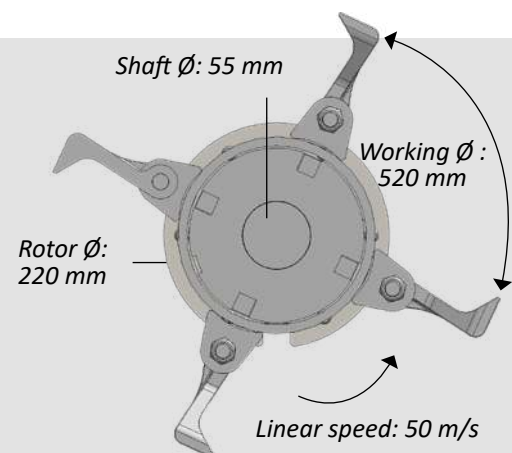

		GB III 220	GB III 250	GB III 280	GB III 310
Dimensions	Working width (m)	2.20	2.50	2.80	3.10
	Overall width (m)	2.38	2.68	2.98	3.28
	Working Ø (mm)	520	520	520	520
	Type of hitch	Double-beam CAT 2 hitch can be offset			
	Offset to the right (mm)	500	500	500	500
	Body structure	8.2-mm body base (5 mm + bolted HDX sheet metal lining, optional), 8-mm side walls			
	Ground following	Ø 194-mm roller, HDX steel lateral skids			
	Weight (kg)	980	1060	1150	1250
Tools	No. of hammers	26	30	34	40
	No. of Y blades	52	60	68	80
	No. of spoon blades	26	30	34	40
	No. of quick-change sickles	52	58	66	—
Features	Gearbox (HP)	160 CV at 540 rpm and 240 CV at 1000 rpm			
	Rotor rotation speed (rpm)	1850	1850	1850	1850
	Linear speed of cutting heads (m/s)	50	50	50	50
	Ejection of shredded matter	Mechanical opening of rear cover, hydraulic opening optional			
	PTO (rpm)	540 / 1000	540 / 1000	540 / 1000	540 / 1000
	PTO shaft	1" 3/8, 6 splines, star tube			
	No. of belts	4	4	4	4
	Required power (HP)	60	70	80	90
Options	1000 rpm option	○	○	○	○
	Hydraulic offset	○	○	○	○
	Hydraulically controlled rear cover opening	○	○	○	○
	HDX sheet metal body lining	○	○	○	○
	HDX sheet metal cover lining	○	○	○	○
	Second counter-blade	○	○	○	○
	Vibration hour meter	○	○	○	○
	Magnetic hour meter	○	○	○	○
	Road signalling kit	○	○	○	○
	Chain guard	○	○	○	○
	360° rear wheels	○	○	○	○
	Set of cutting heads	○	○	○	○

● Standard — Not available ○ Optional



Equipment designed to last

LAGARDE - 65 Avenue de Tréville - 64130 Mauléon Licharre

Tél : +33 5 59 19 20 10 - Fax : +33 5 59 19 20 11 - accueil@lagarde.artzainak.fr



Your LAGARDE dealer